

Techniques in Whole Animal Respiratory Physiology

JJ Cech Jr., University of California, Davis, CA, USA

CJ Brauner, University of British Columbia, Vancouver, BC, Canada

© 2011 Elsevier Inc. All rights reserved.

[Introduction](#)

[Apparatus and Techniques](#)

[Further Reading](#)

Glossary

Active metabolism The maximum aerobic metabolic rate associated with swimming at the greatest sustainable velocity.

Aerobic scope The capacity of an animal to increase its level of aerobic metabolism beyond that which is required for maintenance alone and thereby support activities such as muscular exercise, growth or reproduction; it sets the capacity for oxygen-consuming physiological processes that an animal may perform at a given time. Aerobic scope is the difference between minimal and maximal oxygen consumption rate.

Partial pressure The pressure that a component of a gas mixture would have if it alone occupied the same volume at the same temperature as the mixture.

Respirometer An apparatus used to measure respiratory metabolic rates via indirect calorimetry (e.g., via oxygen consumption or carbon dioxide excretion).

Resting-routine metabolism The metabolic rate for quiescent fish, but not necessarily the lowest rate during the 24-h cycle.

Routine metabolism The metabolic rate including spontaneous movements.

Standard metabolism In ectotherms, this term describes the minimal level of aerobic metabolism (per unit time) required for maintenance functions to sustain life. In this sense, it is analogous to basal metabolism in endotherms, although SMR is strongly influenced by environmental temperature and so it is not always constant within an individual.

Swimming metabolism The metabolic rate measured at some voluntary or forced level of swimming.

Ventilation The movement of the respiratory medium (air or water) over the surface of the gas exchanger.

Ventilation volume The total amount of water pumped over the gills in a period of time (usually 1 min); the product of the rate of breathing multiplied by the volume of water pumped with each breath.

Ventilatory frequency The frequency of buccal or opercular movements.

Ventilatory stroke volume The volume of water pumped per buccal–opercular stroke or movement.

Introduction

Measurements of fish respiratory metabolism and gill ventilation can inform us concerning a fish's physiological state, by providing a quantitative measure of how rapidly energy and oxygen are being converted/used. Data on respiratory metabolic rates are important in the construction of bioenergetic models, and changes in respiratory metabolic and gill ventilatory rhythms can be sensitive indicators of altered environmental conditions or physiological states, and thus can reveal much about a fish's recent and current activity, acclimation, and level of stress. The scope of this article is limited to measurements of respiratory (aerobic) metabolism and gill ventilation.

Respiratory Metabolism Measurement Methods

Metabolic rates can be measured using either direct or indirect calorimetry. Direct calorimetry, the measurement of heat production, is rarely used for fishes because their metabolic and heat production rates are generally low (e.g., compared with those of mammals or birds) and the heat capacity of water is high, which together result in limited measurement sensitivity. Indirect calorimetry, through measurement of oxygen consumption rate (\dot{M}_{O_2}), has become the conventional measure for fishes because changes in dissolved oxygen levels over time in water can be determined with relative ease and reliability. The iodometric or Winkler method of measuring O_2 concentrations (mg or mL O_2 L⁻¹ H₂O) is highly accurate when fresh

reagents are available to fix and titrate water samples and is very useful in the field. Clark-type polarographic electrodes and fiber-optic O_2 sensors (see below) measure O_2 tensions (i.e., partial pressures, P_{O_2}) and are easier and faster to use in the laboratory than the Winkler method. The wide availability and precision of these electrodes have resulted in the rapid expansion of the field of respiration physiology over the past 30 years. Oxygen consumption rate is only an accurate measure of overall metabolism when anaerobic contributions are insignificant. During high-speed sustained and burst swimming or during exposure to hypoxia, metabolic requirements cannot be met aerobically and any deficit is met anaerobically, as indicated by either lactate appearance in the blood or tissues, or an O_2 debt that is repaid during recovery.

In addition to oxygen consumption rate, carbon dioxide (CO_2) production rate can be measured by indirect calorimetry. However, the high solubility of CO_2 in water makes it difficult to measure changes in the partial pressure of CO_2 (P_{CO_2}) accurately with available electrodes, and changes in total CO_2 of the water over time are often difficult to measure against the background CO_2 bound as carbonates and bicarbonates, especially in hard water and saltwater.

Respiratory Metabolism Levels

Aerobic metabolism in fishes can be categorized as standard, resting routine, routine, swimming, and active. Standard metabolism is the minimum metabolic rate for intact fish. Resting-routine metabolism is the rate for quiescent fish, but not necessarily the lowest rate during the 24-h cycle. Routine metabolism is the rate including spontaneous movements. Swimming metabolism rates are measured at some voluntary or forced level of swimming. Active metabolism is the maximum aerobic rate associated with swimming at the greatest sustainable velocity. Aerobic scope is calculated as the difference between active and standard metabolic rates and reflects the aerobic capacity available for everything beyond maintenance, such as growth, reproduction, exercise, and digestion/absorption of food.

The standard (i.e., basal, maintenance, or resting) metabolic rate is the minimum required to sustain life. It should be measured when fish are absolutely quiescent – that is, when they are expending no energy for activity (even random activity), food digestion, reproductive development, growth, or stress responses. Fish should be carefully shielded from changes in water temperature and chemistry and from all disturbances, and they should be given adequate time to habituate to the respirometer. Metabolic rates should be recorded throughout the diel cycle to determine the minimum rate. The innate restlessness of pelagic fishes such as salmon or tuna makes it much more difficult to determine standard metabolism for these species than for demersal or sedentary forms such as flatfishes.

Some workers have calculated standard metabolism from data on swimming fish from relationships between swimming velocity and the logarithm of metabolic rate via extrapolation to zero velocity. Besides the statistical problem (i.e., widening confidence limits) associated with extrapolation, the physiology (e.g., via hormone secretions) of active and quiescent fish may be quite different.

The resting-routine metabolic level falls between standard and routine metabolism. Measurements of resting-routine metabolism require a quiescent fish without food in its gut, a respirometer with dimensions that constrain swimming but are not overly confining, and isolation of the fish from laboratory stimuli. However, these measurements do not account for the diel activity cycles that fish normally undergo.

Most metabolic values reported for fishes are routine rates, which represent generally quiescent to moderately active fish. Routine metabolic rates include spontaneous activity, possibly due to daily activity cycles, and they may include swimming at a velocity of up to 1 body length s^{-1} .

Swimming metabolic rates are measured during various voluntary or forced levels of swimming. Active metabolic rates are generally defined as those attained while a fish is swimming at the greatest sustainable velocity for a particular period of time, such as 1 h.

Gill Ventilation

Oxygen uptake across the respiratory surfaces is driven by diffusion. The rate of O_2 diffusion is directly proportional to the partial-pressure gradient (see also **Ventilation and Animal Respiration: Efficiency of Gas Exchange Organs and Respiratory Gas Exchange During Development: Models and Mechanisms**). Because the movement of ventilation water over the gills replaces the boundary layer of water next to the lamellar epithelium (where O_2 is diffusing inward), thus maintaining the P_{O_2} gradient between water and blood, gill ventilation is an essential respiratory process in most fishes (see also **Ventilation and Animal Respiration: Efficiency of Gas Exchange Organs**). Ventilation volume is the total volume of water forced over the gills. Ventilatory frequency is the frequency of buccal or opercular movements, and ventilatory stroke volume is the volume of water pumped per buccal–opercular stroke or movement. Percentage utilization of oxygen is the percentage of available oxygen removed by respiration from the inspired water.

Apparatus and Techniques

Oxygen Measurements

Oxygen dissolved in water is usually measured electrometrically or titrimetrically (e.g., with Winkler titrations). One common electrometric measurement system uses

the Clark-type oxygen electrode. This electrode consists of an anode (e.g., silver–silver chloride) and a cathode (e.g., platinum), which are bathed in an electrolytic solution in the electrode body. An O₂-permeable membrane is stretched across the electrode tip. When a small polarizing voltage is applied across the anode and cathode, O₂ diffusing across the membrane is reduced at the cathode, producing a small electrical current through the electrode. This current is proportional to the P_{O₂} in the water. The current is amplified and displayed on a meter or digital readout; the display equipment varies from battery-powered portable units to bench-top units with computer interfaces. Because of possible drifting, calibration of Clark-type O₂ electrodes should be checked frequently. Some dissolved oxygen meters use fiber-optic oxygen sensors, which may require less-frequent calibration and maintenance and, unlike the Clark-type oxygen electrode, do not consume O₂. Whereas some meter and electrode systems for dissolved oxygen automatically calculate O₂ concentrations (e.g., mg O₂ L⁻¹) from detected O₂ tensions if water temperature and salinity values are known, other units display P_{O₂} (e.g., in millimeters of mercury (=torr) or kilopascals). These can be converted to O₂ concentration (usually mL O₂ L⁻¹) with the aid of a nomogram or oxygen solubility tables and the formula

$$C_{O_2}(ws) = P_{O_2}(ws)C_{O_2}(AS) / P_{O_2}(AS) \quad (1)$$

where C_{O₂}(ws) is the O₂ concentration (mL O₂ L⁻¹) in the water sample, P_{O₂}(ws) the O₂ tension (mmHg) in the water sample, C_{O₂}(AS) the O₂ concentration in water at air saturation (from nomogram or tables), and P_{O₂}(AS) the O₂ tension at air saturation (from eqn (2)). Oxygen concentrations in mL O₂ L⁻¹ can be converted to mg O₂ L⁻¹, assuming 1.428 mg O₂ mL⁻¹ O₂.

The oxygen tension at air saturation is

$$P_{O_2}(AS) = 0.2094(P_B - P_{WV}) \quad (2)$$

where 0.2094 is the mole fraction or volumetric fraction of O₂ in the atmosphere, P_B the total barometric pressure (mmHg), and P_{WV} the water vapor pressure at the experimental temperature (mmHg).

Overall, it is imperative that water samples from respirometers be taken with the minimum possible exposure to the atmosphere. Where continuous monitoring of water O₂ tension is desired, fiber-optic oxygen sensors may be placed directly in the respirometer, provided the water volume is adequately mixed. Fiber-optic oxygen sensors or Clark-type electrodes can be housed outside the respirometer in a thermostatically controlled chamber where water is drawn from the respirometer, forced past the electrode, and returned to the respirometer in a closed loop driven by a peristaltic pump.

Body Mass Considerations

Large fish generally consume more O₂ than small fish. However, on a unit-mass basis, small fish consume more O₂ than large fish. This allometric relationship can be described as

$$Y = aX^b \quad (3)$$

or

$$\log_{10} Y = \log_{10} a + b \log_{10} X \quad (4)$$

where *Y* is the O₂ consumption rate (mg O₂ min⁻¹), *a* the mass coefficient, *X* the body mass (g or kg), and *b* the mass exponent (see also **Energetics: Physiological Functions that Scale to Body Mass in Fish and Ventilation and Animal Respiration: Respiratory Gas Exchange During Development: Respiratory Transitions**).

The log–log plot of *X* and *Y* (eqn (4)) is a linear one, but with a slope (*b*) that usually is less than 1.0. Consequently, to compare metabolic rates of different-sized fish, O₂ consumption rate cannot simply be divided by fish mass (i.e., mg O₂ g⁻¹ h⁻¹), and both intra- and interspecific comparisons of respiratory metabolic rates must be conducted carefully. For intraspecific comparisons, it is best if the mean body masses of the two groups are statistically indistinguishable and the ranges around those means are small. If the two groups of fish have significantly different mean masses, one of two other analyses might be appropriate. The first is an analysis of covariance with mass as the covariate, and the other is to determine the actual mass exponent (e.g., *b* = 0.81) for the particular group of fish and divide the raw data by (mass^{*b*}). This last technique yields mass-independent metabolic rates that are most correctly analyzed in log₁₀-transformed form. These two analyses are also appropriate when different species of fish are compared, although their regression intercepts (mass coefficients, *a*, eqns (3) and (4)) may vary (see also **Energetics: General Energy Metabolism**). Finally, mass exponents should be determined over as wide a size range (e.g., one to two orders of magnitude) of homomorphic (i.e., of same body proportions) individuals as possible.

Respiratory Metabolism

A respirometer incorporates a chamber for the fish and a surrounding respiratory medium (usually water, though air or access to air may be appropriate). There are essentially two types of respirometers: closed respirometers, in which the same volume of respiratory medium is continuously used with little replacement, and open respirometers, in which the medium is continuously replaced. Closed respirometers are of two types: static respirometers and swimming respirometers. In static respirometers, the medium is not moved in directed

currents, though it may be kept well mixed by gentle stirrers and the fish itself. In swimming respirometers, water flows within the vessel, forcing the fish to swim against a directed current. In contrast, fresh water continually flows into and out of open (or flow-through) respirometers, the object being to maintain water quality. In general, static and open respirometers are used to measure similar aspects of fish respiration, though the measurements are made differently. Swimming respirometers can be quite elaborate and expensive. Whatever system is chosen, the study will progress most efficiently if several replicate setups can be used simultaneously.

Static Respirometers

A static respirometer contains a circulating, fixed volume of water at constant temperature. It may be as simple as a glass jar or flask and a tight-fitting stopper to which water-sampling and water-flushing tubes have been fitted (**Figure 1**), or a probe that has been inserted directly. The jar or other container should be impermeable to gases and at least partially transparent to allow detection of bubbles. Because air contains up to 30 times more O₂ per unit volume than water, bubbles, as potentially a great source of respirometry error, must be removed. A transparent chamber may also help the enclosed fish to visually orient to the environment (e.g., experimental tank or stream bottom) in which the respirometer is placed, and thereby to acclimate to the

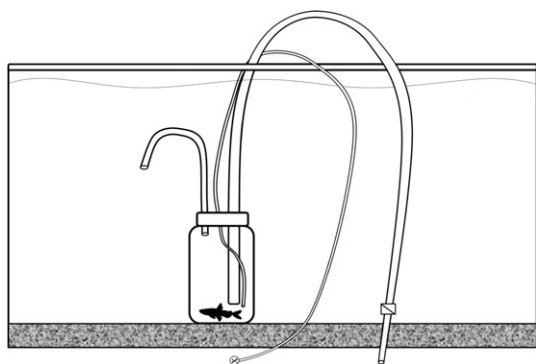

Figure 1 Static, closed respirometer (situated in an aquarium), consisting of a glass jar with rubber stopper through which siphon tubes can flush aquarium water through the respirometer during fish acclimation to the respirometer. The outflow siphon tube is equipped with a tubing clamp (depicted by a rectangle surrounding a diagonal line) to shut off the flushing flow during an experiment. Initial and final water samples are collected in a syringe (not shown) via the small-diameter water-sampling tube and attached stopcock (depicted by a circle surrounding an 'x'). The fish's small movements and gill ventilation circulates the water inside the respirometer. Redrawn by R. Coulter from Cech JJ (1990) Respirometry. In: Schreck CB and Moyle PB (eds.) *Methods for Fish Biology*, pp. 335–363. Bethesda, MD: American Fisheries Society.

confines of the respirometer. Some species (e.g., gobies (Gobiidae) and toadfish (Batrachoididae), which have secretive habits), however, acclimate more readily if the vessel is nearly opaque.

Measurements of O₂ consumption are calculated from changes in dissolved O₂ concentration over time, taking into account the respirometer volume:

$$\dot{M}_{O_2} = (C_{O_2(A)} - C_{O_2(B)})V/T \quad (5)$$

where \dot{M}_{O_2} is the O₂ consumption rate (mg O₂ h⁻¹), $C_{O_2(A)}$ the O₂ concentration in water (mg O₂ L⁻¹) at the start of the measurement period, $C_{O_2(B)}$ the O₂ concentration in water (mg O₂ L⁻¹) at the end of the measurement period, V the volume of respirometer (L), and T the time elapsed during measurement period (h).

Corrections for microbial O₂ consumption or production can be made by accounting for the O₂ consumed from a blank (fishless) respirometer with dimensions and tubing lengths similar to those of respirometers containing fish. Some investigators measure microbial O₂ consumption rates in the fish's respirometer after the fish is removed, a correction technique that is especially recommended for extended metabolic studies because microbial dynamics may differ between experimental and blank vessels.

The volume of the respirometer should generally be 30–50 times that of the fish. A respirometer that is smaller than this may stress the test fish and elevate respiratory metabolic rates. In one that is larger, the time required to measure \dot{M}_{O_2} may be prohibitively long and the fish's ventilatory and fin movements will not keep the water mixed well enough to assure the investigator of representative samples in which case additional stirring mechanisms may be required. Submersible pumps add heat energy to the system, which could affect metabolic rates.

Considerable effort should be made to minimize stress. When fish must be moved, they should be transferred quickly from one tank to another using a vessel (e.g., beaker or bucket) that will prevent air exposure. If possible, the water source and quality should be the same in the respirometers' water bath as it is in the fishes' holding tank. The tank containing the respirometers should be at least partially covered to shield test fish from the glare of lights and the movement of people. Fish should be guided carefully into the respirometer opening. The respirometers can be slowly flushed with water from the respirometer tank (e.g., with a siphon, **Figure 1**) while the fish is initially settling down and between experiments. When the measurement period begins, the outflow tubing normally is clamped off and either the decline in O₂ levels within the system is continuously monitored, or initial and final water samples are taken for O₂ analysis. The outflow tube may be used for this purpose, especially if large samples are needed for Winkler titrations, but a small-diameter, heavy-walled sampling tube is recommended if

only a few milliliters are needed. The dead-space water filling the sampling tube is easily removed with syringes and a three-way stopcock (Figure 1). Small water samples insure that replacement water drawn into the respirometer from the water bath has minimal effect on the final O_2 measurement. Spontaneous activity from fish in routine metabolic states can be quantified using video recordings of fish, especially if the respirometers have grid marks on the walls.

Special static respirometers can be used to isolate the respiratory contributions from different gas-exchange sites. For example, some respirometers may incorporate a rubber sleeve to separate branchial from cutaneous compartments. In each compartment, the water is circulated past an oxygen electrode by a pump, allowing O_2 consumption rates from each gas-exchange site to be measured separately. Special (e.g., L-shaped, with a gas space at the top of its vertical arm) static respirometers that incorporate an air phase can be used to study respiration by fishes with air-breathing organs (e.g., lung and swimbladder). Changes in volume and O_2 content in the gas space allow calculation of instantaneous O_2 consumption rates.

Because fish eventually deplete the O_2 in the enclosed volume of water, the main limitations of the static respirometer concern long-term experiments, especially those in which fish are to be exposed to prolonged stable levels of hypoxia. For metabolic studies under normoxic conditions, measurements must be made before chamber P_{O_2} declines to a critical level. Flushing the respirometer with hypoxic water permits \dot{M}_{O_2} measurements at predetermined hypoxic P_{O_2} ranges.

Dissolved metabolic wastes (CO_2 and ammonia) also increase during static experiments. Automated systems that incorporate intermittent flows have solved some of the problems inherent in long experiments with static respirometers.

Open (Flow-Through) Respirometers

Open respirometers (Figure 2) solve many of the problems that arise during long-term studies with static systems. Continuous flows of water over the fish eliminate the need for periodic flushing flows; wastes do not accumulate, and desired characteristics such as oxygen concentration are maintained.

Under stable environmental conditions, oxygen consumption rates are calculated by the equation

$$\dot{M}_{O_2} = (C_{O_2}(I) - C_{O_2}(O))FR \quad (6)$$

where \dot{M}_{O_2} is the O_2 consumption rate ($mg\ O_2\ min^{-1}$), $C_{O_2}(I)$ the O_2 concentration in inflowing water ($mg\ O_2\ L^{-1}$), $C_{O_2}(O)$ the O_2 concentration in outflowing water ($mg\ O_2\ L^{-1}$), and FR the water flow rate through the respirometer ($L\ min^{-1}$).

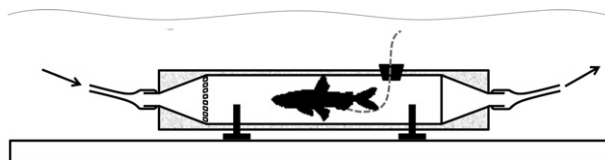

Figure 2 Open (i.e., flow-through) respirometer (situated in a tank of water), consisting of clear acrylic pipe with tapered ends to smooth the slow, continuous flow of water through the respirometer. Note that the inflowing water tube (shown cutoff in this diagram) would be attached (e.g., via a manifold with a port to measure dissolved oxygen) to a constant-head reservoir. The inflowing water would pass through the baffle plate (shown upstream of the fish) in which the perforating holes are drilled at angles to minimize eddy creation in the respirometer. The outflowing water tube (also shown cutoff) would lead to a rack where water could be sampled for dissolved oxygen and captured over a fixed time to measure flow rate. The rubber stopper and dashed line show a possible arrangement for leading an indwelling cannula (e.g., for blood-gas measurements) from the fish out of the respirometer. Not shown is the hatch or removable (rear) end cap through which the fish is inserted and removed from the respirometer. Redrawn by R. Coulter from Cech JJ (1990) Respirometry. In: Schreck CB and Moyle PB (eds.) *Methods for Fish Biology*, pp. 335–363. Bethesda, MD: American Fisheries Society.

To avoid using a time-lag correction factor, fish should be quiescent and water conditions should not change quickly in the flow-through respirometer. To check that the desired slug of water moves through the respirometer without mixing or creating major eddies, flow properties can be checked by injecting dye into the inflow water and observing its pattern through the chamber.

Automated designs incorporate computers or timers (e.g., with solenoid valves) to divert water past a calibrated O_2 electrode.

Generally, water flow rates are set so that the difference in oxygen concentration between inflowing and outflowing water is $0.5\text{--}1.0\ mg\ L^{-1}$. Water flows are typically measured as the weight ($1\ g = 1\ mL$) or volume of outflowing water collected per unit time. Water flowmeters may also be used, but they usually are not precise enough for metabolic calculations.

Flow-through respirometers are generally constructed of clear, thick-walled acrylic plastic such as Plexiglas[®]. Some kind of inert, virtually gas-impermeable tubing (e.g., a heavy-walled transparent vinyl such as Tygon[®]) directs the inflowing water to this chamber. This tubing should be as short as possible to minimize the buildup of attached organisms, and should be of the same length on multiple respirometers if these are used. It is important to spread the flow from the small-diameter tubing across the larger diameter of the chamber without creating eddies or dead spaces. Smooth-walled cones connecting the two and a baffle plate usually serve this function (Figure 2).

Swimming Respirometers

Swimming respirometers usually contain a closed volume of water that is circulated past a fish, inducing the fish to swim. As in static systems, changes in dissolved oxygen concentration through time in the enclosed volume reflect the rate of respiratory metabolism, in this case at a particular swimming velocity. Two basic designs of swimming respirometers are in current use. The most common is the water tunnel or Brett-type respirometer, which consists of a closed loop of pipe containing a centrifugal pump or propeller connected to an electric motor (Figure 3). A variable-speed drive on the motor changes the water velocity past the fish. The fish is restricted to its chamber by screens, flow-straightening tubes, or an electrifiable grid at the rear of the chamber. Gradual turns of custom-bent polyvinyl chloride pipe in the tunnel loop and gradual tapers ($<25^\circ$) in sections connecting the swimming chamber with other pipes minimize turbulence and temperature increases. Alternatively, a closed loop of pipe of constant diameter allows faster water velocities to be achieved with the same-size motor. However, the somewhat larger volume of the constant diameter system will result in longer experiments, due to the slower change in water P_{O_2} because of metabolism.

Water velocity through the swimming chamber is proportional to pump speed, measured in revolutions of the pump shaft per minute. Water velocity should be measured with an electronic flowmeter, and then compared with speed settings on the motor or pump shaft. After this calibration, water velocity can be determined by measuring pump speed with a tachometer. A correction factor for solid blocking effect must be applied if the test fish occupies more than 10% of the cross-sectional area of the

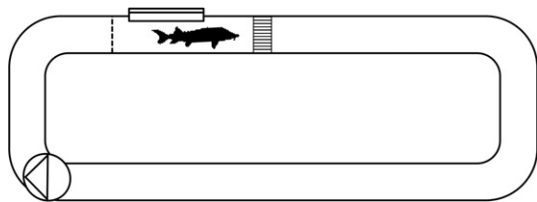

Figure 3 Brett-type, swimming closed respirometer is a loop of pipe (e.g., PVC, with a clear acrylic section for the fish), which incorporates either a propeller or a pump (shown as a circle surrounding a triangle) powered by a variable-speed motor (not shown) to push water past the fish. Flow-straighteners are shown upstream and a screen (dashed line) is shown downstream of the fish. The hatch above the fish, for insertion and removal of the fish, is shown as an acrylic saddle and rubber gasket over the top of the acrylic pipe (not intruding into the smooth, constant diameter of this respirometer). Not shown are sampling tubes for dissolved oxygen measurements. Redrawn by R. Coulter from Cech JJ (1990) *Respirometry*. In: Schreck CB and Moyle PB (eds.) *Methods for Fish Biology*, pp. 335–363. Bethesda, MD: American Fisheries Society.

swimming chamber. Automated versions of the Brett-type respirometer may incorporate a computer-controlled system that re-oxygenates respirometer water via an artificial lung perfused with O_2 gas between bouts of oxygen-consumption rate measurements.

The second basic swimming respirometer (Blazka) design is based on concentric (coaxial) tubes; the swimming chamber is in the inner tube and water returns between the inner and outer tubes (Figure 4). A propeller, driven by a variable-speed electric motor, or a submersible water pump pulls or pushes water past the fish and returns it to the front of the swimming chamber via the outer tube after it is deflected by a domed cap. The spiraling movement imparted to the water by the rotating propeller can be minimized by replacing the conventional propeller with a jet outboard impeller and by incorporating flow-straightening vanes in the outer tube and small-diameter tubes at the ends of the inner tube. The small-diameter tubes, which may vary in diameter from thin-walled 1.25-cm polyvinyl chloride pipe in larger Blazka respirometers to 3-mm plastic soda straws in small ones, also confine the fish to the swimming chamber. The respirometer may also have an electrified wire grid (8–10 V AC) behind the fish to encourage it to swim if required. The relatively small water volume of the Blazka design minimizes the time needed to measure oxygen consumption rates at a particular temperature and swimming velocity.

Metabolic rates of swimming fish have also been estimated from heartbeat, ventilation, and swimming muscle contraction frequencies by telemetry. These telemetric techniques point the way to improved *in situ* metabolic measurements, although activities that require different muscles (i.e., without inserted electrodes) may not yield accurate metabolic estimates.

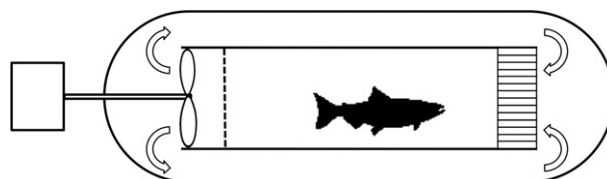

Figure 4 Blazka-type, swimming closed respirometer is an acrylic tube within a larger acrylic tube. A variable-speed motor (rectangle) turns a propeller, drawing water past the fish. The end caps recirculate the water (depicted by the arrows) between the outer and inner tubes, through the flow straighteners (upstream of the fish) and the screen (depicted by the dashed line downstream of the fish). Not shown are the hatches or removable end caps to insert and remove the fish, or the sampling tubes for dissolved-oxygen measurements. Redrawn by R. Coulter from Cech JJ (1990) *Respirometry*. In: Schreck CB and Moyle PB (eds.) *Methods for Fish Biology*, pp. 335–363. Bethesda, MD: American Fisheries Society.

Gill Ventilation

Gill ventilation is accomplished in two ways: water is actively pumped by the buccal–opercular apparatus, or it is passively forced over the gills as fish swim, called ram ventilation. Ram ventilation requires only that a fish maintains a buccal–opercular gape while it swims at or above a threshold velocity, which is thought to conserve energy. Active pumping of gill ventilation water is commonly measured in a respirometer that directs ventilatory water flows into a container or past a flow probe. Respirometers designed for water collection usually incorporate a thin rubber membrane or mask fitted to the fish's head to separate inspired from expired water for measurements of ventilation volume. The fish is situated in a two-chamber (van Dam-type) respirometer with the membrane sealing the barrier between the two chambers except for the fish's head (Figure 5). The water levels in both chambers are set to the same height by adjustment of surface drains so that hydrostatic pressure does not aid or inhibit gill ventilation. Water continuously flows into the anterior chamber (any excess flows out through the surface drain) and is moved from the

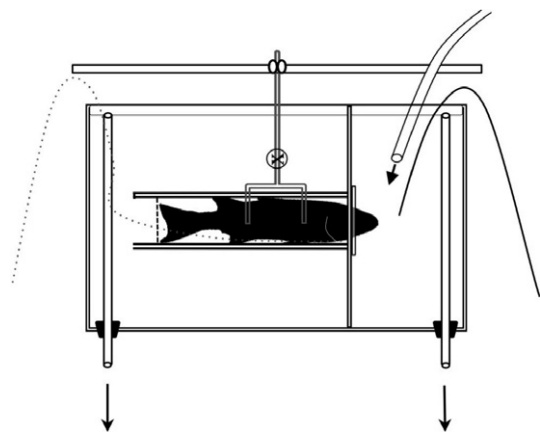

Figure 5 Two-chamber (van Dam-type) respirometer is a clear box (e.g., aquarium), incorporating a clear wall separating the two chambers. The fish is suspended in an acrylic box, so that its head partially protrudes through a hole in a light-gauge latex sheet, which is stretched over a large hole in the separating wall. Thus, the fish acts as a pump to move water from the anterior to the posterior chamber. A constant flow in inflowing water (top, right) enters the anterior chamber, and water not pumped by the fish escapes through the anterior chamber's surface drain (bottom, right). The water displaced by the fish's ventilatory pumping escapes through the posterior chamber's surface drain (bottom left). This flow is collected for a fixed time for the ventilation volume measurement. Note that the two surface drains are adjusted so that the water depths in the anterior and posterior chambers are equal. The solid and dashed lines represent water-sampling tubes for dissolved-oxygen measurements of inspired and expired water, respectively. Redrawn by R. Coulter from Cech JJ (1990) Respirometry. In: Schreck CB and Moyle PB (eds.) *Methods for Fish Biology*, pp. 335–363. Bethesda, MD: American Fisheries Society.

anterior to the posterior chamber only by the fish's active ventilation. As the fish ventilates its gills, water equal to the ventilation volume is displaced from the posterior chamber via the posterior surface drain. This water is collected for a time as a measure of ventilation volume. Ventilatory movements of the buccal or opercular apparatus can be counted visually or detected with immersed electrodes sutured to the external opercula and connected to an amplifier and computer. Measured simultaneously over a specified time period, the frequency of ventilation (F_G , movements min^{-1}) and the volumetric rate of ventilation (\dot{V}_G , mL min^{-1}) allow calculation of ventilatory stroke volume (V_S , mL/movement : $V_S = \dot{V}_G/F_G$). Simultaneous measurements of oxygen concentrations in inspired and expired water, sampled near the mouth and gills, permit estimation of the oxygen consumption rate by the Fick equation:

$$\dot{M}_{O_2} = \dot{V}_G(C_{O_2}(I) - C_{O_2}(E)) \quad (7)$$

where \dot{M}_{O_2} is the O_2 consumption rate ($\text{mg } O_2 \text{ min}^{-1}$); \dot{V}_G is the volumetric ventilation rate (mL water min^{-1}); $C_{O_2}(I)$ is the O_2 concentration in inspired water ($\text{mg } O_2 \text{ mL}^{-1} \text{ water}$); and $C_{O_2}(E)$ is the O_2 concentration in expired water ($\text{mg } O_2 \text{ mL}^{-1} \text{ water}$).

Because these oxygen consumption rates are calculated from oxygen concentrations immediately adjacent to the mouth and gills, they may underestimate total respiration because cutaneous gas exchange can represent an important proportion of total oxygen uptake, even for scaled fishes.

Percentage utilization (% U) of oxygen taken up at the gills can be calculated from the same data. Either oxygen tensions or concentrations can be used in this measure of the gills' oxygen extraction efficiency:

$$\begin{aligned} \% U &= (P_{O_2}(I) - P_{O_2}(E)) / P_{O_2}(I) \times 100 \\ &= (C_{O_2}(I) - C_{O_2}(E)) / C_{O_2}(I) \times 100 \end{aligned} \quad (8)$$

where $P_{O_2}(I)$ is the O_2 tension of the inspired water (mmHg) and $P_{O_2}(E)$ is the O_2 tension of the expired water (mmHg).

The energetic cost of gill ventilation has been determined by comparison of oxygen consumption rates at velocities below and above the transition from active ventilation to passive ram ventilation on sharksuckers, which are similar to remoras, attached to the inside of a tunnel respirometer by their dorsal cephalic suction disks. (see **Ventilation and Animal Respiration: Respiratory Gas Exchange During Development: Respiratory Transitions**).

See also: **Energetics: General Energy Metabolism; Physiological Functions that Scale to Body Mass in Fish. Ventilation and Animal Respiration: Respiratory Gas**

Exchange During Development: Models and Mechanisms; Efficiency of Gas Exchange Organs.

Further Reading

Bridges CR and Butler PJ (1989) *Techniques in Comparative Respiratory Physiology: An Experimental Approach, Society for Experimental Biology Seminar Series*, p. 351. Cambridge: Cambridge University Press.

Cech JJ (1990) Respirometry. In: Schreck CB and Moyle PB (eds.) *Methods for Fish Biology*, pp. 335–363. Bethesda, MD: American Fisheries Society.

Gehrke PC, Fidler LE, MenseDC, and Randall DJ (1990) A respirometer with controlled water quality and computerized data acquisition for experiments with swimming fish. *Fish Physiology and Biochemistry* 8(1): 61–67.

Steffensen JF (1989) Some errors in respirometry of aquatic breathers: How to avoid and correct for them. *Journal of Fish Physiology and Biochemistry* 6: 49–69.